

SAW Filters: Performance Characteristics (Part I)

Roshni Prasad
Associate Engineer – RF & Antennas
Abracon, LLC

Abstract: The increased use of radios for wireless applications, such as military, commercial, medical, and navigational designs, demands the use of several filter networks within the transceiver chain. Radios exchange signals over common wireless channels, which introduces signal interference and crosstalk among co-existing radios in an application. A filter helps suppress or eliminate undesired signals like signal interference, crosstalk, harmonics, and jamming signals to render usable signal into the radio system. A surface acoustic wave (SAW) filter is ideal for use in applications requiring filters from 10 MHz to 3 GHz. This white paper discusses the advantages, design criteria, and material choices for SAW filters along with a detailed overview of SAW filter performance characteristics.

Index

Why SAW Filters?

Filter Structure & the Piezoelectric Effect

SAW Filter Materials

Performance Characteristics of SAW Filters

Nominal Frequency (F_n)

Insertion Loss (IL) & Amplitude Ripple (AR)

Q Factor (Q) & Shape Factor

Temperature Coefficient and Compensation

Impedance

Power Rating

Package

Conclusion

References

Why SAW Filters?

SAW filters offer many advantages over other filter types for RF and IF filtering in today’s wireless circuits in terms of size, selectivity, and performance while having good control over the insertion and rejection bands. This is possible because of technological advancements in package miniaturization, reproducibility, and cost effectiveness.

- The wave velocity of an acoustic wave through a SAW substrate is about 10^5 times lower than that of an electromagnetic (EM) wave in free space. In other words, the wavelength in a SAW device can be 10^5 times shorter than an EM wave.[1] This property enables miniaturization of SAW devices.
- The wide range of crystal composition and crystal cutting techniques help achieve a suitable quality (Q) factor. This allows for both high selectivity compared to LC and dielectric filters as well as wide bandwidths.
- SAW filters offer excellent control over frequency with high reproducibility in mass production through microfabrication technique. While reproducibility is a bit effortless for simple low-cost structures, it is especially a challenge in the design and fabrication of SAW devices for channelized receivers.
- The flexibility in cost allows expansion in the usage of SAW filters into a wide range of applications. Their simple, low-cost structures are suitable for high-volume requirements such as cellular devices. Whereas specialized, high-cost devices are more suitable for low-volume applications such as radar signal processing.

Filter Structure & the Piezoelectric Effect

A SAW filter operates based on the piezoelectric effect – thus converting electrical signals into mechanical acoustic waves and back. The device configuration consists of two interdigital transducers (IDTs), an input and an output, in combination with a piezoelectric elastic surface (substrate). Fig. 1 below represents a simple SAW filter structure consisting of an input and output IDT, a substrate, an absorber and a connection to source and load with suitable matching networks.

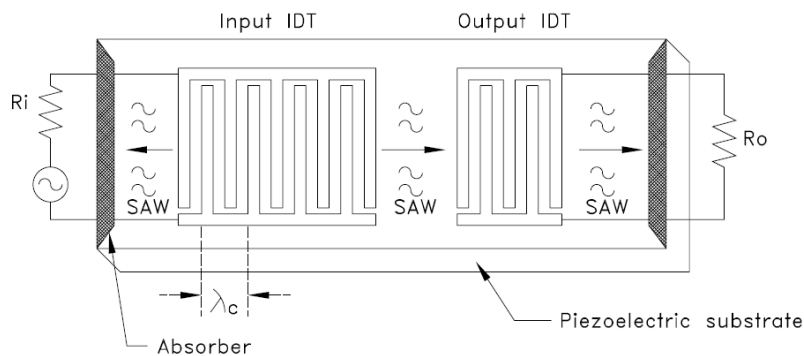

Fig. 1: Simple SAW Structure

The IDTs behave as delay lines. Thus, the frequency of operation is determined based on wave velocity

and periodicity of the IDT design. The efficiency of the piezoelectric effect is determined by the SAW velocity and the electro-mechanical coupling coefficient (K^2) of the substrate. The signal processing in the device and the frequency response are mainly governed by the geometry and alignment of the IDTs. The waveform generated in a SAW filter approximates a sinusoidal wave. [1]

There are two common types of IDT structures employed for SAW filter designs. They include uni-directional IDT and bi-directional IDT. [2]

- **Uni-directional IDTs (UDT):** When IDTs excite the SAW toward one direction, they are referenced as UDTs. Single UDTs are the simplest and most common type used in front-end RF circuits. Two or multi-phase UDTs are employed in applications requiring low loss structures at high frequencies ($1 \text{ dB} \leq \text{Insertion Loss} \leq 10 \text{ dB}$). These are perfect candidates for mass volume requirements due to lower costs. The fractional bandwidths can vary from 1% to 100%.
- **Bi-directional IDTs:** When IDTs excite the SAW toward either direction with equal amplitude, they are referenced as bi-directional IDTs. While single IDTs are commonly used for controlled frequency response, double IDTs are employed to suppress more reflections and obtain steep response due to their periodicity. [2] Band pass filters with linear phase response and defined non-linear phase response are commonly obtained through the design ($6 \text{ dB} \leq \text{IL} \leq 60 \text{ dB}$). The fractional bandwidths are usually less than 5%.

SAW Filter Materials

While SAW filter performance is mainly dependent on K^2 (which affects the fractional bandwidth) and velocity of propagation (which affects the group delay), the two parameters are greatly dependent on the elasticity, density and piezoelectric properties of the substrates used. Hence, the materials for SAW filters are selected based on their elasticity, loss characteristics, temperature coefficients of frequency or delay, and, most importantly, piezoelectricity presence. [3]

The material's crystal cut, axis of wave propagation, and IDT alignment control the wave velocity, piezoelectric coupling, diffraction, attenuation, beam steering, and level of unwanted bulk-wave generation. For example, based on the combination of material and cut angle, coupling coefficients (K^2) could be tuned between 0.1% to 15%. [4]

The following table highlights the widely used substrate types for SAW filter designs. [5][6]

Table 1: Substrate Types for Saw Filter Designs

Filter Type	Substrate Material	Crystal Cut	Velocity (m/s)	Temperature Coefficient - T_c (ppm/ $^{\circ}\text{C}$)	Coupling Coefficient - K^2	Feature
Narrow Bandwidth	Quartz	ST, Y	3158	-0.036 (PPM/ $^{\circ}\text{C}^2$)	0.0011	Ultra-high selectivity / Poor Coupling / High Temperature Stability
	Lithium Tantalate	112 $^{\circ}$	3290	18	0.0075	High selectivity / Low Coupling / Good Temperature Stability
Narrow-to-Mid Bandwidth		42 $^{\circ}$	4022	40	0.076	Strong Coupling / Moderate Temperature Stability
Wide Bandwidth	Lithium Niobate	127.86 $^{\circ}$	3992	75	0.053	Good Coupling / Poor Temperature Stability
		YZ	3488	94	0.045	

Of the parameters discussed in the above table, the temperature coefficient shifts the center frequency with respect to operating temperature. Coupling coefficient dictates how efficiently the material produces acoustic waves and, hence, the loss characteristic. Velocity dictates the group delay, which is inversely proportional to SAW filter’s fractional bandwidth.

- For narrow band filters, the ultra-high selectivity and elevated temperature stability of quartz makes it an ideal candidate. While ST-cut is commonly employed, LST-cut shows superior performance. [7]
- For narrow and moderate bandwidths, insertion loss is easily optimized using Lithium Tantalate substrates. The LiTaO₃ 112° cut is employed for selectivity between the quartz and LiTaO₃ 36/42° cuts. [8][9]
- For wide band filters and radar pulse compression filters with exceptionally large time-bandwidth, the relatively high coupling coefficient of Lithium Niobate makes it a more suitable substrate. The YZ-cut has high performance due to its low diffraction case. The 128° cut is particularly suited for bulk-wave generation. [10]
- Additionally, Gallium Arsenide (GaAs) is used for IC-based SAW designs. It exhibits better attenuation characteristics and lower coupling than quartz.

Performance Characteristics of SAW Filters

The operating bandwidths of a SAW filter can range from a very narrow bandwidth (about 2 MHz to 10 MHz) to designs with wide bandwidths (up to a few hundred MHz). In the bandwidths of interest, SAW filters can offer excellent stability, precise frequency control, steep skirt, and excellent rejection. The following section details each of the performance metrics that defines the characteristics of a SAW filter.

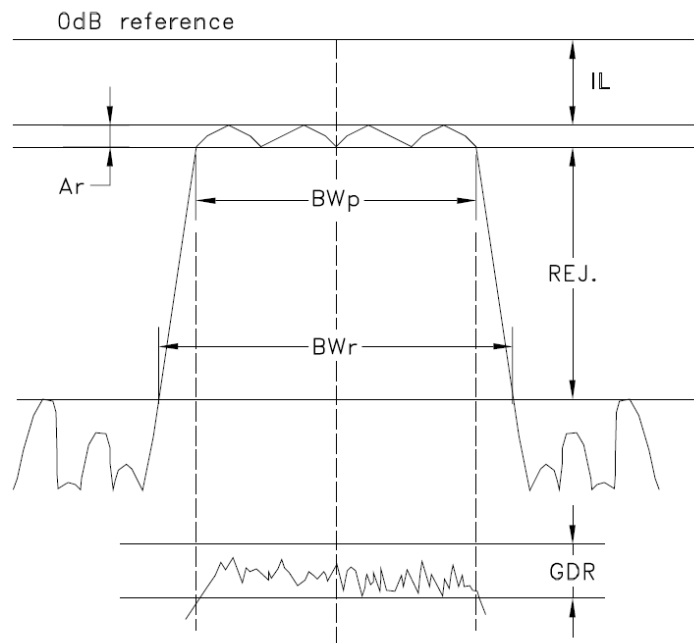

Fig. 2. A typical band pass filter characteristic is shown.

Nominal Frequency (Fn)

- Nominal frequency (Fn) is the usable bandwidth where transmission or reception of signals is observed. It is also the range of frequencies covered by 3dB or by the half-power bandwidth represented as BWp in Fig. 2. In practice, the filters used are mostly band pass type; sometimes notch filters are used. A band pass filter response is indicated with filter skirts on either side of the pass band, as indicated in Fig. 2.
- In SAW filter design, the material choice, which is proportional to the coupling coefficient, greatly determines the maximum allowable bandwidth. Quartz is preferred for ultra-narrow band applications, whereas 112° and 36°/42° Lithium tantalate cuts are preferred for lower and wider bandwidths, respectively. Lithium niobate is also of interest for high frequency wide bandwidth signal processing applications. [8][11]
- The fabrication dimensional accuracy of the IDT and the alignment of the crystal propagation axis critically decide the sidelobe suppression level. While a 30 dB rejection is mostly attainable, improving attenuation characteristics over this may rapidly become challenging, especially with diffraction. Diffraction is a second-order effect that defines the bending of waves and causes transfer function distortion as indicated in Fig. 3. [12]

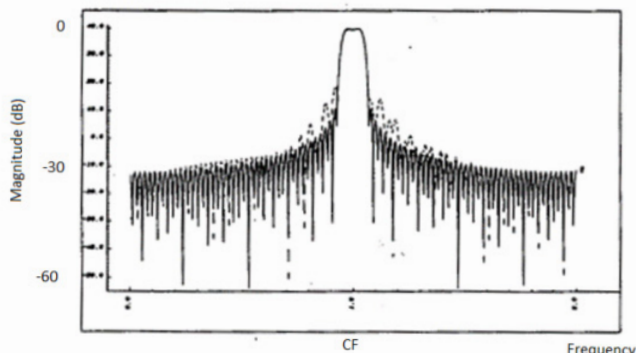

Figure 5 : Ideal and diffracted responses of 30 dB SAW filter

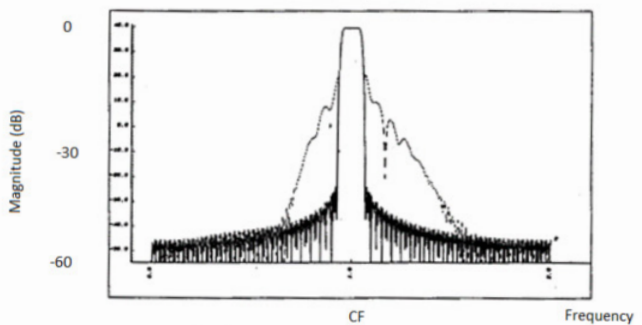

Figure 6 : Ideal and diffracted responses of 60 dB SAW filter

Fig. 3 Diffraction

- While the actual bandwidth is determined at 25°C room temperature, the frequency of operation may drift with respect to the temperature coefficient of the substrate used at different operating temperatures. [9]

Insertion Loss (IL) & Amplitude Ripple (AR)

- The signal loss incurred when an input signal travels through the filter is indicated by insertion loss (IL). The variations in the IL within the desired pass/stop band are indicated as amplitude ripple (AR) in Fig. 2.
- In any filter design, the insertion loss worsens toward the pass band edges and causes distortion of modulated signals.
- Further, the IL and AR in the pass band are interdependent with the rejection characteristics. For example, filters with steep roll-off suffer overall insertion loss. For this matter, the two parameters require optimization based on a desired goal.
- For higher order filters, there is also a tradeoff between the ripple overshoot issue and the phase

linearity maintenance.

- A SAW filter's insertion loss is limited by the coupling coefficient and the Q-factor of the substrate material used.

$$IL \approx 10 \log_{10} \frac{\pi^2}{(2K^2)^2} \left(\frac{\Delta f}{f_0} \right)^4.$$

Triple Transit (TT)

- Triple transit (TT) represents undesired wave reflections in the SAW device and affects the overall insertion loss through constructive and destructive interference. There is secondary degradation in ripple, phase linearity and group delay and hence needs to be suppressed during the design and optimization phase.
- In a standard SAW filter, TT is related to the insertion loss as follows:

$$TT = (IL * 2) + 6 \text{ dB}$$

- Design-inherent distributed mechanical reflections are introduced in single phase UDTs to cancel the wave reflections in the SAW device and therefore retain a lower insertion loss.

Group Delay (GDR)

- Group delay (GDR) indicates the time taken for the wave to travel inside the substrate from the input to the output end at different frequencies within the bandwidth of interest. So, GDR is proportional to the length of the network.
- GDR also represents the rate of change between the transmission phase angle with respect to the frequency. Group delay is expressed in micro-second (us) or nano-second (ns) units.

$$GDR = \frac{-\Delta\Phi}{\Delta f}$$

Where $\Delta\Phi$ is the change in phase angle and Δf represents the change in frequency

- GDR is mainly dependent on the material wave velocity. Also, it is proportional to the filter order and inversely proportional to the filter bandwidth. Hence, for narrow bandwidths, GDR is almost a constant but exhibits a variation in wide bands and near the pass band edges.
- In linear phase SAW filter design, the maximum attainable time (group) delay is proportional to the separation between the IDTs and is limited by the substrate length. Even with limited substrate length, the maximum attainable delay is optimized by using a non-linear phase design with negative values of relative phase shift added at center frequency.
- On the application end, particularly in radar systems, a flat and consistent group delay is of prime importance over a span of GHz as they accurately measure distances.

Q Factor (Q) & Shape Factor

- The quality (Q) factor determines the maximum intrinsic bandwidth (BW) of a filter and is simply the measurement of stored energy to the dissipated energy. In other words, the quality factor of a filter can be defined as the ratio of center frequency (CF) to its 3 dB BW (BWp).

$$Q = \frac{CF}{BW_p}$$

- Shape factor also indicates the selectivity of the filter. It is the ratio of a filter’s out-of-band attenuation (say 60 dB) to the in-band attenuation (say 3 dB).

$$\text{Shape Factor} = \frac{BW_r}{BW_p}$$

With a higher Q, tighter BW filter configurations with less rounded edges are achievable, as indicated in Fig. 4. And, with lower shape factor, steeper filter skirts can be designed.

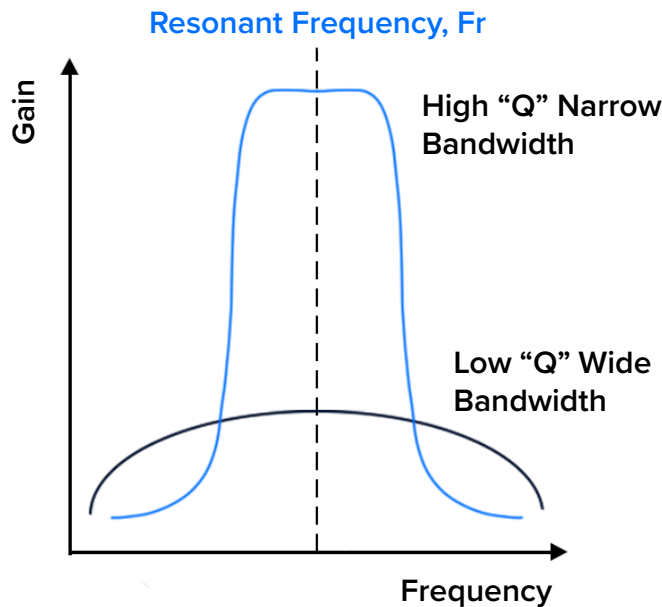

Fig. 4: Filter – Q factor and Shape factor

- To achieve a desirable Q in SAW filter design, the coupling coefficient (K^2) of the piezoelectric substrate and the number of finger pairs, which determines the order of the filter, are optimized. A higher K^2 and longer finger pairs are optimal to achieve higher Q.

Temperature Coefficient and Compensation

- The temperature coefficient indicates the respective frequency shift associated with the changes in temperature. Temperature compensation refers to the measure of counteracting any frequency drift with changes in temperature.
- One of the prime factors impacting the reliability performance of SAW filters is internal temperature increases due to any power dissipations. The power dissipation heats the device and causes distortion in the filter response. The self-heating also has major impacts – causing frequency shifts in the filter characteristics. Therefore, it is necessary to understand the material, crystal cut and IDT reliability criteria to optimize the filter design.
- Quartz exhibits extremely low temperature dependence over frequencies and is well suited for narrow band applications. With other crystals/substrates for SAW filter designs, discussed in “Materials” section on page 4, temperature-dependent frequency drift is anywhere from -20 ppm/°C to -40 ppm/°C. This is undesirable, especially for many narrow band applications.

- Temperature-compensated SAW (TC-SAW) technology, on the other hand, aims to offer better performance by reducing or eliminating frequency shifts over temperature. For example, this is possible through the concept of multi-layer wafer bonding and through certain material combinations. One way of achieving this is by using LiTaO₃ 42°-YX cut/Si/Cu tri-layer structures with thick Al electrodes that exhibit 0 ppm/°C. [13] This technology is particularly desirable for narrow bands with minimal duplex gaps such as in the 5G/LTE cellular frequencies. [14]

Impedance

- The impedance parameter defines the percentage of power transfer from the source to load and is the complex ratio of voltage to current.
- Typical SAW filters operate at 50-ohm input impedance and at about 100- to 200-ohm output impedance (usually in differential) with a single external matching inductor. The SAW filter can include an acoustic balun, which allows for differential signal creation. At low impedances, a SAW filter suffers resistive loss; At high impedances, parasitic capacitance related to the substrate becomes a problem. The input impedance is frequency dependent and is obtainable by performing Fourier transform of the impulse response across all frequencies of interest. The amplitude of impulse response depends on the amount of overlap between the two fingers of opposite polarity in an IDT at any given point and at that time. By modifying the overlap between the fingers, the IDT's impulse and frequency response can be optimized, and hence the input impedance. [12][15]

Power Rating

- The continued trend in reducing package size while pushing for increased power levels and higher data rates places demanding design constraints on RF acoustic filters for compact, high-end applications such as mobile phones.
- The maximum power handling capacity of a SAW package under varying temperature conditions is indicated as power rating. The nominal power rating for today's low power SAW filter ranges from 0 dBm to around 25 dBm.
- Increased signal power facilitates good signal strength during transmission and helps distinguish the desired signal from the noise floor. But the filter's power handling capacity is limited by the material property and the structural design of the IDT in efficiently dissipating heat.
- Additionally, the range of a wireless system is dictated by transmission power level. A continuous wave transmission operates at peak power (with duty cycle as one), whereas a pulsed wave transmission system has an average operating power several times lower than the peak power. Hence, a continuous wave transmission has a higher range than the pulsed wave transmission for the same peak power.
- A pulsed transmission over shorter intervals, however, will have less effect on the filter itself over its lifetime; although, a continuous wave operation is supportable over its lifetime.

Package

- In common, a higher filter performance requires larger packaging. A greater package size offers more room for complex design optimization and additional filter sections to better control the filter skirt.
- Over the years, package sizing has decreased from 5.0 x 5.0 mm to 1.1 x 0.9 mm. Especially with wafer level packaging (WLP) technique for the 1.1 x 0.9 mm, ultra-compact and reliable filter components with superior performance have been achievable.
- The filter packages are hermetically sealed and can be of several types, including Leadless Chip Carrier (LCC), dual inline package (DIP), flatpack in addition to WLP.
- Additionally, miniaturization poses challenges to the design structures, tolerance levels and demands more accuracy in fabrication – photolithography and patterning processes. The device also requires

about 2 to 4 mask layers for connections between the internal layers. [4]



AFS303.825E
 $5 \times 5 \times 1.5 \text{ mm}^3$
 $5 \times 5 \times 1.35 \text{ mm}^3$



AFS915S3
 $3.8 \times 3.8 \times 1.5 \text{ mm}^3$



AFS1575.42S4
 $3 \times 3 \times 1.5 \text{ mm}^3$
 $3 \times 3 \times 1.28 \text{ mm}^3$



AFS20A02-1575.42-T2
 $2 \times 1.6 \times 0.9 \text{ mm}^3$



AFS14A04-1575.42-T2
 $1.4 \times 1.1 \times 0.7 \text{ mm}^3$



ABSTS5A2-45HM03BM
 $1.1 \times 1.1 \times 0.9 \text{ mm}^3$

Conclusion

Filters, in particular SAW-based filters, are necessary for many wireless applications in military, radar, telecommunication, bio-medical and recently IoT devices. The wide variety of crystal material compositions and crystal cuts enable SAW filters to be excellent candidates for both narrow and wide bandwidth filtering. In addition, material selection plays a significant role in determining the efficiency, loss, and frequency stability criteria of the filter with respect to temperature variations. Like material selection, the IDT design plays a huge role in optimizing the impedance and frequency characteristics of the filter.

Some applications require exceptionally low insertion loss at the receiver chain, especially when used as the first component next to the antenna, to maintain a lower cascading noise figure and to pass on maximum power input to the chipset. Other applications may require incredibly low insertion loss during transmission to pass high power signals with minimal loss, hence decreasing the heat loss and signal distortion. There are also scenarios that require exceedingly high attenuation in the stop band to reject undesired or jamming signals at the receiver.

To achieve application-specific requirements, several trade-offs with secondary effects such as triple transit (TT) and diffraction will need to be addressed during the design process. Hence, the selection of substrate material as well as the crystal cut, filter design and characteristics will need to be optimized to suit specific application needs.

Abrakon has recently introduced its 1.0x0.9mm packaged, miniature SAW filter family, ideally suited for WiFi, GNSS, LPWA and ISM applications. This offering extends Abrakon's existing SAW filter portfolio which encompasses industry standard packaged solutions in 5x5, 3.8x3.3, 3x3, 2x1.6 and 1.4x1.1mm. The ABSTS family in 1.0x0.9mm package offers superior selectivity for space-constrained applications across multiple protocols.

Part II of this white paper will address application specific examples outlining the advantages of Abrakon SAW filters.

Author Information:
 Roshni Prasad
 Associate Engineer – RF & Antennas
 Abrakon, LLC

References

- 1] H. P. M. Hugo, "Computer aided design and analysis of SAW filters," COMSIG 88@m_Southern African Conference on Communications and Signal Processing. Proceedings, 1988, pp. 71-75, doi: 10.1109/COMSIG.1988.49305.
- 2] Hashimoto, Ken-Ya. Surface Acoustic Wave Devices in Telecommunications: Modelling and Simulation. Germany: Springer Berlin Heidelberg, 2013.
- 3] R. Weigel et al., "Microwave acoustic materials, devices, and applications," in IEEE Transactions on Microwave Theory and Techniques, vol. 50, no. 3, pp. 738-749, March 2002, doi: 10.1109/22.989958.
- 4] R. Aigner, "SAW and BAW technologies for RF filter applications: A review of the relative strengths and weaknesses," 2008 IEEE Ultrasonics Symposium, 2008, pp. 582-589, doi:10.1109/ULTSYM.2008.0140.
- 5] Campbell, Colin. Surface Acoustic Wave Devices and Their Signal Processing Application. Academic Press, Inc., 2021.
- 6] "Introduction to SAW Filter Theory & Design Techniques," RF Cafe. [Online]. Available: <https://www.rfcafe.com/references/app-notes-copyrighted/SAW-Filter-Theory-Whitepaper-API-Technologies.pdf>
- 7] C. S. Lam and D. E. Holt, "A comparison of temperature performance of SAW filters made on ST- and LST-cut quartz," IEEE 1988 Ultrasonics Symposium Proceedings., 1988, pp. 273-278 vol.1, doi: 10.1109/ULTSYM.1988.49382.
- 8] "Lithium Tantalate (LiTaO3)", The Roditi International Corporation. [Online]. Available: <http://www.roditi.com/SingleCrystal/Lithium-Tantalate/LiTaO3.html>
- 9] J. -. Hode, M. Doisy and P. Dufilie, "Application of low loss SAW filters to RF and IF filtering in digital cellular radio systems," IEEE Symposium on Ultrasonics, 1990, pp. 429-434 vol.1, doi: 10.1109/ULTSYM.1990.171402.
- 10] "Lithium Niobate Wafers," The Roditi International Corporation. [Online]. Available: <http://www.roditi.com/SingleCrystal/LiNbO3/LiNbO3-Wafers.html>
- 11] "Lithium Niobate", The Roditi International Corporation. [Online]. Available: <http://www.roditi.com/SingleCrystal/LiNbO3/LiNbO3.html>
- 12] H. P. M. Hugo, "Computer aided design and analysis of SAW filters," COMSIG 88@m_Southern African Conference on Communications and Signal Processing. Proceedings, 1988, pp. 71-75, doi: 10.1109/COMSIG.1988.49305.
- 13] K. Bhattacharjee, A. Shvetsov and S. Zhgoon, "Temperature Compensation in SAW Filters by Tri-Layer Wafer Engineering," 2007 IEEE International Frequency Control Symposium Joint with the 21st European Frequency and Time Forum, 2007, pp. 189-193, doi: 10.1109/FREQ.2007.4319061.

14] J. Costa et al., “Design and characterization of SAW filters for high power performance,” 2017 IEEE International Ultrasonics Symposium (IUS), 2017, pp. 1-4, doi: 10.1109/ULTSYM.2017.8091515.

15] Kemp, Jonathan A., “Input impedance from the input impulse response”. Kemp Acoustics. [Online]. Available: <http://www.kempacoustics.com/thesis/node58.html>