

LAN Transformers:

Magnetic elements of the physical layer in local area networks

Power & Energy Engineering Team
Abracon, LLC



Introduction

As image and video processing increase in customer demand, communication systems are trending toward higher data rates. To support these needs, sophisticated wired and wireless systems have been developed. Although wireless devices have seen rapid growth over the last decade, wired devices remain the backbone of the communication infrastructure by supporting higher data rates through fiber and copper mediums. As each medium has associated cost, performance and design tradeoffs, fiber and copper dominate wired networks with support by the IEEE 802.3 standard.

A typical local area network (LAN) endpoint comprises of several layers organized in the OSI model defined by the IEEE 802.3 consortium. Please refer to the IEEE OSI model for definitions of the layers. The first layer, known as the PHY (physical) layer, consists of electrical interface requirements like differential signaling, electrical isolation and filtering. This application note will focus on the electrical interface of the PHY layer.

For a communication system to sustain data rates that comply with IEEE requirements, it is important to minimize the bit error rate (BER) as seen by the PHY. Data transmission through an unshielded twisted pair (UTP) is highly susceptible to electromagnetic interference (EMI) from the surrounding environments.

Since all Base-T cabling is defined as UTP, completely isolating the lines from each other and their surroundings becomes impractical from a cost standpoint. The solution partly lies in the quality of the twisted pair cabling and the magnetics utilized for reducing noise imposed upon these copper lines.

To understand how the transformers are utilized for filtering out noise, it is important to first know the signals used in local area networks.

Signal Description

LAN utilizes either 2 or 4 pairs of differential signals depending on the data rate as part of the scheme for enhancing signal integrity at the physical layer. In its simplest encoding scheme, data appears in the form of square waves with encoding techniques dependent on the data rate. **Table 1** summarizes the pairs used for each data rate as defined by the IEEE 802.3 standards.

Standard	Data Rate	Differential Pairs	Channel Operating
802.3i	10 Base-T	2	1 pair TX 1 pair RX
802.3u	100 Base-TX	2	1 pair TX 1 pair RX
802.3ab	1000 Base-T	4	4 pair Bidirectional
802.3bz	2.5G Base-T	4	4 pair Bidirectional
802.3bz	5G Base-T	4	4 pair Bidirectional
802.3an	10G Base-T	4	4 pair Bidirectional

Table 1: IEEE standards for data rates and required pairs

Differential Signal

Differential pairs supply a potential across a terminated load, causing current to flow to the PHY without reference to ground. This is beneficial for long transmission of a signal and for removing the signal from a potentially noise-prone ground. This voltage is defined as V_{diff} , the difference between the positive (V_{TD+}) and the negative (V_{TD-}) lines. **Figure 1** illustrates the differential signal.

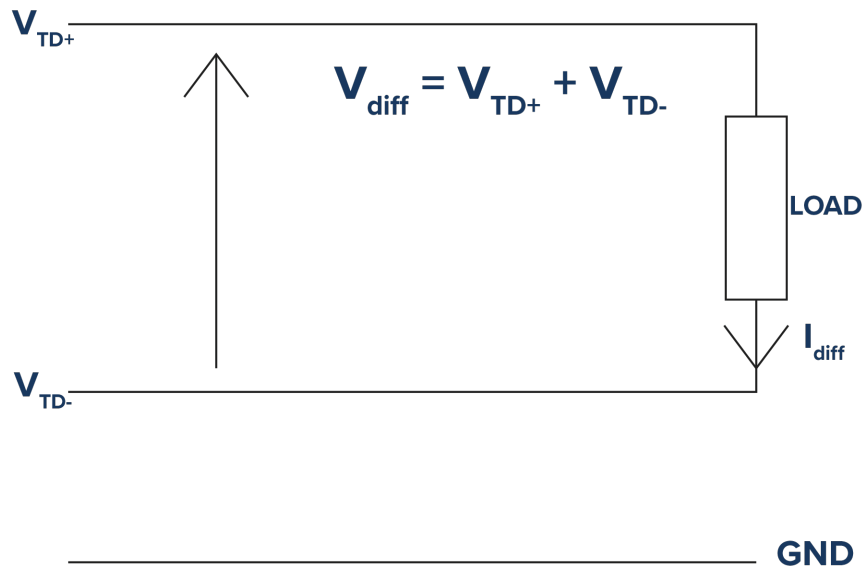

Figure 1: Differential signal transmission

As evidenced in **Figure 2**, ideal differential signals are defined as possessing the following characteristics:

1. Equal in amplitude
2. 180 degrees out of phase

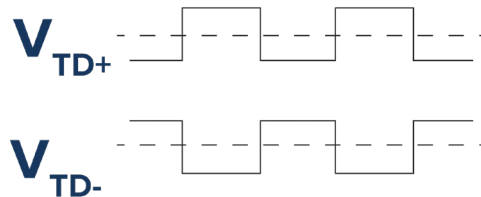

Figure 2: Ideal differential signal

In reality, the signal delivered to the PHY can have deviation in amplitude and phase. It will have EMI on the 2-line channel, also referred to as common mode noise.

Common Mode Signal

The common mode signal is a direct result of noise on the lines caused by voltage supplies, RF signals and coupling due to other devices in close proximity. As referenced in **Figure 3**, ideal common mode signals are defined as having the following:

1. Equal in amplitude
2. 0 degrees out of phase

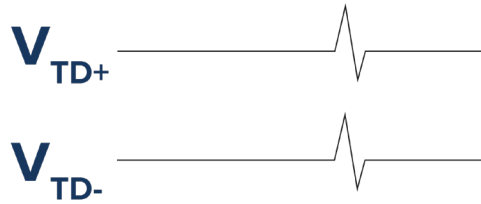

Figure 3: Ideal common mode signal

This common mode signal is superimposed on the differential signal causing unreliable voltage drops across the load due to current through parasitics. The result of these changes in current can cause the PHY chip to misinterpret a piece of data in the data stream as an incorrect symbol. Misinterpreted data will often be detected and there will be a request for retransmission, decreasing effective system throughput.

It is important to identify this type of signal and apply appropriate technology to suppress the common mode noise. The common mode signal is defined as V_{comm} , the difference between V_{diff} and ground. **Figure 4** illustrates the common mode signal.

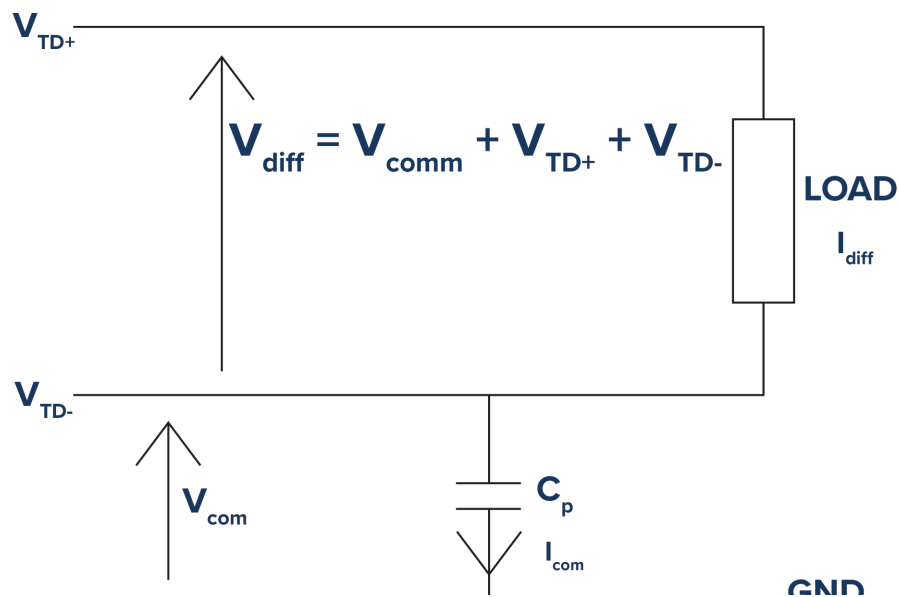

Figure 4: Total signal transmission

Solution

The LAN magnetics are used to limit the common mode noise while also providing isolation from the transmit and receive devices. **Figure 5** illustrates a generalized block diagram of the relationship between the cable feeding the signal into the magnetics and PHY chipset.

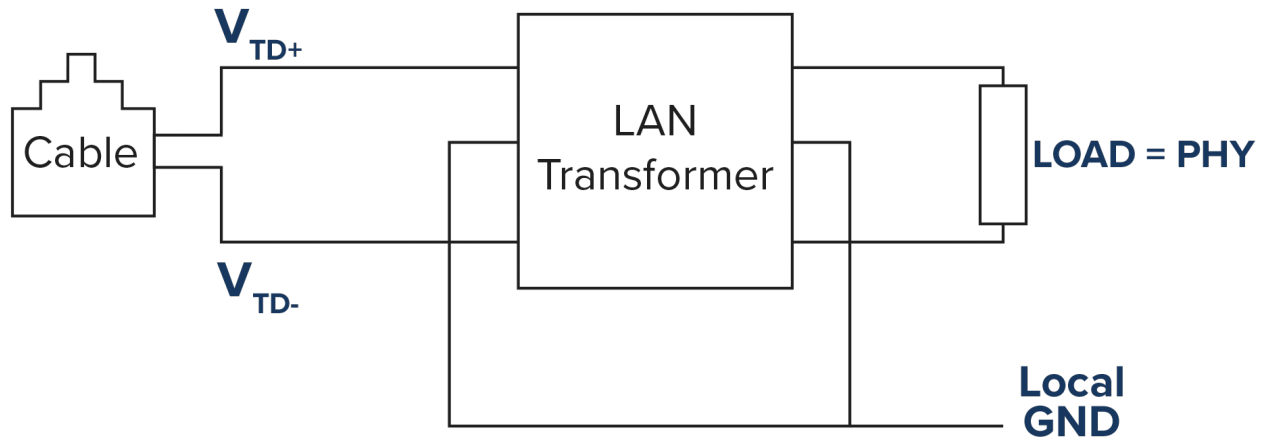

Figure 5: Conceptual interpretation of the physical layer

LAN magnetics can consist of any combination of transformer, common mode choke and shunt inductor/ autotransformer. Each component filters common mode noise in a unique way. **Figure 6** illustrates an example of a single channel with a transformer, a common mode choke and an autotransformer (from left to right, respectively).

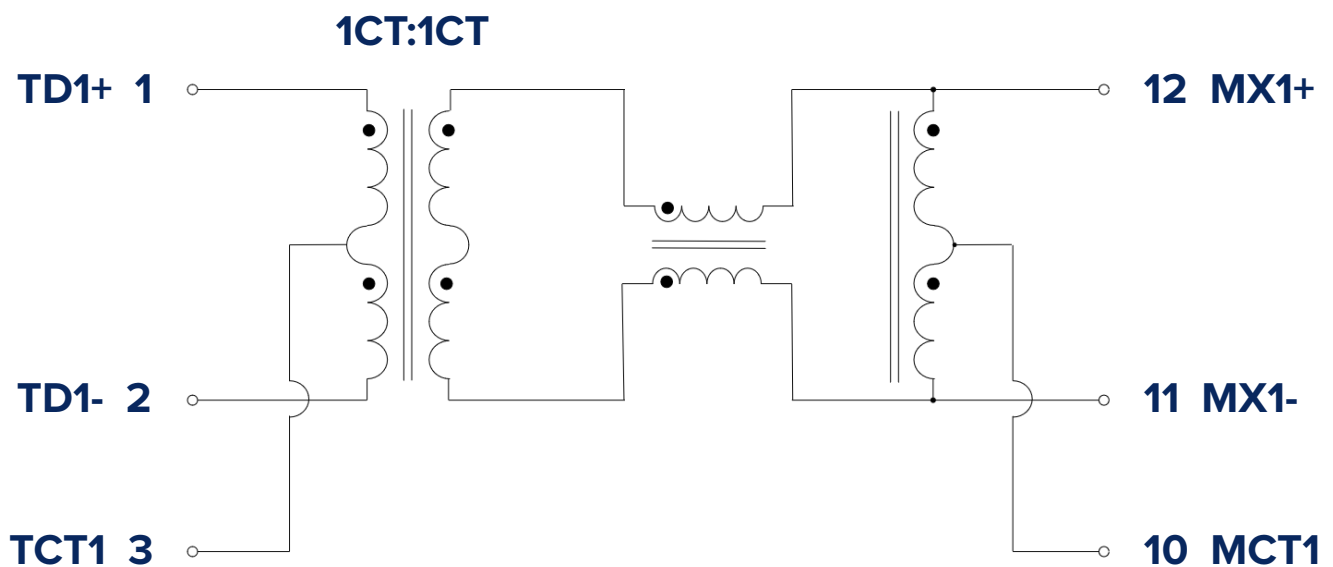

Figure 6: Example of a single LAN magnetics channel

Transformer

The transformer is multifunctional in ethernet applications. First, it filters common mode noise, and secondly, it provides electrical isolation between the transmit device and the cabling. The transformer uses mutual coupling to transfer the signal from the primary winding to the secondary winding, typically at a 1:1 ratio with each side center tapped to ground.

On the primary side, the differential pairs are wound in opposite directions with respect to the center tap, creating a magnetic field through the core at a strength proportional to the difference between the positive and negative lines.

At the secondary side, the windings are also wound in a fashion to recreate the positive and negative differential signals based on the induced magnetic field through the center of the magnetic core. Because of the winding direction, the common mode current flows to ground through the center tap. Some of the common mode signal passes through the transformer due to interwinding capacitances between the primary and secondary windings.

Since the transformer uses mutual coupling to transfer the signal, the two endpoints are electrically isolated from the cabling and each other. The isolation between the devices is imperative for negating unexpected, high voltage signals from damaging end devices. As specified in the 802.3 standard, isolation of 1500V between the primary and secondary winding is required. Higher isolation up to 8000V may be required for ruggedized applications. Testing for transformer isolation performance is often referred to as high potential (Hipot) testing.

Common Mode Choke

The common mode choke rejects common mode noise by imposing high impedance to the common mode signal and low impedance to the differential signal. The common mode signal is reflected to pass through other ground points or dissipated as heat due to lossy characteristics of the choke. The physical construction of the common mode choke is generally with a different type of material than the transformer. This technique is utilized to take advantage of different permeability for filtering at different frequencies.

Shunt Inductor/Autotransformer

The shunt inductor/autotransformer is a center tapped ferrite that allows additional common mode filtering for applications with noisy environments such as the automotive industry or applications with many peripheral devices in confined spaces. The line sees low impedance to ground for common mode noise causing the common mode current to run to ground. On the other hand, the differential signal sees high impedance through the core and passes the magnetics. These shunt inductors are used when reliability has greater importance but the implementation for these types are not always necessary. Since it adds an additional component, the cost is likely to increase as well.

Conclusion

Ethernet-twisted pair cabling and magnetics have been designed to support our everyday internet and communication needs. The inherent nature of wired signal transmission causes signal distortion over any given medium due to imperfections in material as well as impractical isolation from other systems. Utilizing magnetic material in ethernet applications can help suppress common mode noise that occurs from transmission.

Whether a transformer, common mode choke and autotransformer is used depends on the specific environment and requirements of the application. Abracon offers a very wide and easily selectable range of LAN transformer offerings that all meet the 802.3 standard. Please see **Table 2** for reference.

Abracon Series	Data Rate	Port Counts	Advantage
ALANS	100 Base-TX 1000 Base-T	1 & 2	High Voltage Isolation, Operating Temp up to -55°C ~125°C
ALANL	100 Base-TX 1000 Base-T	1	Low Profile
ALAN1	100 Base-TX 1000 Base-T	1	POE: 15W Devices
ALAN2	100 Base-TX 1000 Base-T	1	POE+: 30W Devices
ALAN3	100 Base-TX 1000 Base-T	1	POE++IUPOEI4POE: 60/90W Devices
ALANQ	100 Base-TX 1000 Base-T	1	Automotive Coming soon

Table 2: Abracon magnetic series with features and advantages

Author Information:
Power & Energy Engineering Team
 Abracon, LLC