

# ABS07-120-32.768kHz-T; TUNING FORK CRYSTAL



3.2 x 1.5 x 0.9 mm

32.768kHz SMD; ESR OPTIMIZED CRYSTAL



**Moisture Sensitivity Level (MSL) – This product is Hermetically Sealed and not Moisture Sensitive - MSL = N/A: Not Applicable**

## FEATURES:

- Guaranteed ESR of 60kΩ Maximum for Low Power Designs
- 0.9mm height ideal for high density circuit boards
- Seam sealed ceramic package offers excellent environmental & heat resistance
- Extended Operating temperature of -40°C to +85°C for industrial applications

## APPLICATIONS:

- Power sensitive designs requiring Low ESR Crystal, such as ST-Micro MCU STM32L based solutions
- Communication & measurement equipment
- Commercial, Consumer & Industrial applications
- Wireless communications
- PDA and Smartphone

## STANDARD SPECIFICATIONS

Parameters	Minimum	Typical	Maximum	Units	Notes
Frequency		32.768		kHz	
Operation Mode	Tuning Fork				
Operating Temperature	-40		+85	°C	
Storage Temperature	-55		+125	°C	
Frequency Tolerance @+25°C	-20		+20	ppm	Tested at 0.1uW
Temperature Coefficient:	-0.045	-0.035		ppm/T <sup>2</sup>	
Turn-over temperature:	+20	+25	+30	°C	
Equivalent series resistance (R1)		55	60	kΩ	
Shunt capacitance (C0)			1.60	pF	
Motional capacitance (Cm)		3.0 ~ 6.0		fF	
Load capacitance (CL)		6.0		pF	
Drive Level		0.1	0.5	μW	
Q value	13000				
Aging@25°C±3°C	-3		3	ppm	First year
Insulation Resistance	500			MΩ	@ 100Vdc ± 15V

## PART IDENTIFICATION: ABS07-120-32.768 kHz-T

## FREQUENCY VARIATION OVER OPERATING TEMPERATURE; RELATIVE TO MEASURED FREQUENCY AT 25°C

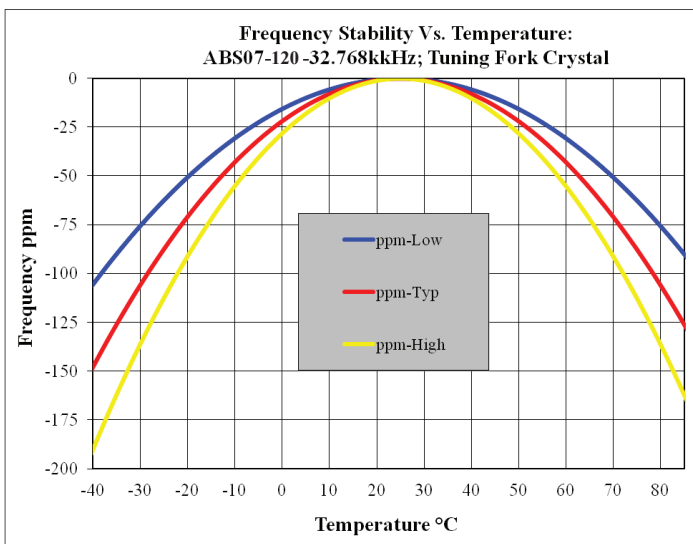

Temp °C	(ppm) Low	(ppm) Typ	(ppm) High
-40	-105.63	-147.88	-190.13
-35	-90.00	-126.00	-162.00
-30	-75.63	-105.88	-136.13
-25	-62.50	-87.50	-112.50
-20	-50.63	-70.88	-91.13
-15	-40.00	-56.00	-72.00
-10	-30.63	-42.88	-55.13
-5	-22.50	-31.50	-40.50
0	-15.63	-21.88	-28.13
5	-10.00	-14.00	-18.00
10	-5.63	-7.88	-10.13
15	-2.50	-3.50	-4.50
20	-0.63	-0.88	-1.13
25	0.00	0.00	0.00
30	-0.63	-0.88	-1.13
35	-2.50	-3.50	-4.50
40	-5.63	-7.88	-10.13
45	-10.00	-14.00	-18.00
50	-15.63	-21.88	-28.13
55	-22.50	-31.50	-40.50
60	-30.63	-42.88	-55.13
65	-40.00	-56.00	-72.00
70	-50.63	-70.88	-91.13
75	-62.50	-87.50	-112.50
80	-75.63	-105.88	-136.13
85	-90.00	-126.00	-162.00



5101 Hidden Creek Ln Spicewood TX 78669  
 Phone: 512-371-6159 | Fax: 512-351-8858  
 For terms and conditions of sales, please visit:  
[www.abracon.com](http://www.abracon.com)

REVISED: 05-26-21

ABRACON IS  
 ISO9001-2015  
 CERTIFIED

# ABS07-120-32.768kHz-T; TUNING FORK CRYSTAL

32.768kHz SMD; ESR OPTIMIZED CRYSTAL

 RoHS/RoHS II



3.2 x 1.5 x 0.9 mm

## OUTLINE DRAWING:

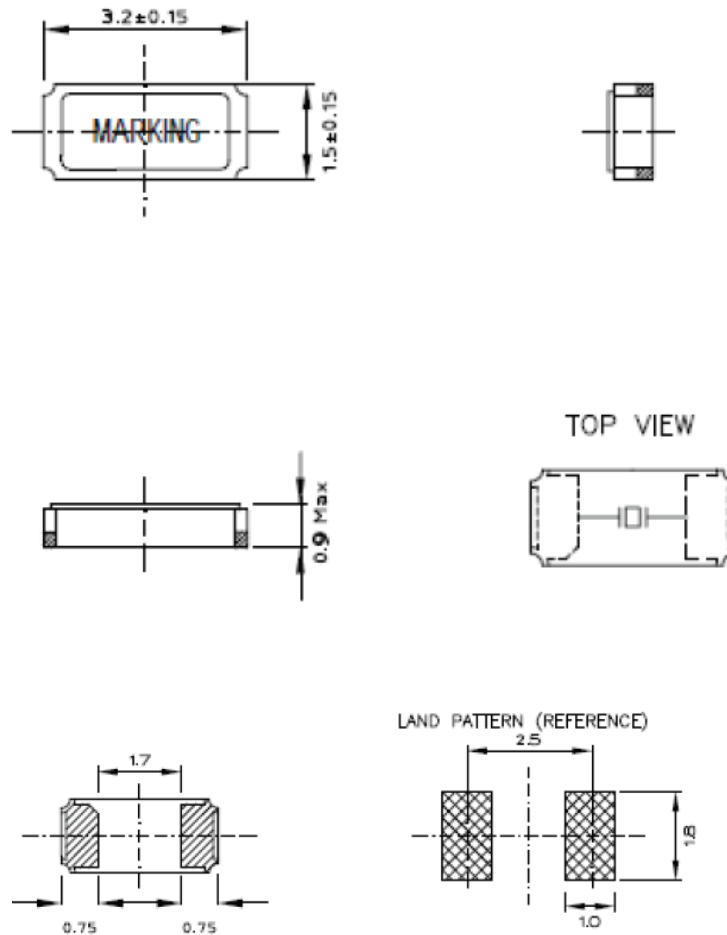

Dimensions: mm

# ABS07-120-32.768kHz-T; TUNING FORK CRYSTAL

32.768kHz SMD; ESR OPTIMIZED CRYSTAL



3.2 x 1.5 x 0.9 mm

## Reflow Profile [JEDEC J-STD-020]

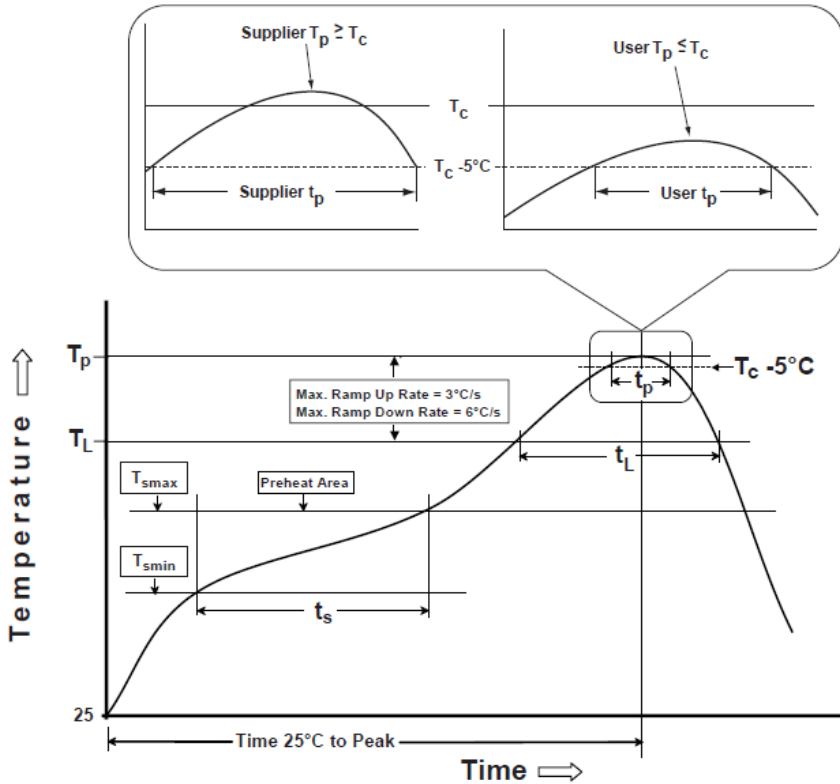

Table 1

SnPb Eutectic Process Classification Temperatures ( $T_c$ )		
Package Thickness	Volume $\text{mm}^3$ <350	Volume $\text{mm}^3$ >350
<2.5 mm	235 °C	220 °C
>2.5 mm	220 °C	220 °C

Table 2

Pb-Free Process Classification Temperatures ( $T_c$ )			
Package Thickness	Volume $\text{mm}^3$ <350	Volume $\text{mm}^3$ 350-2000	Volume $\text{mm}^3$ >2000
<1.6 mm	260 °C	260 °C	260 °C
1.6 mm - 2.5 mm	260 °C	250 °C	245 °C
>2.5 mm	250 °C	245 °C	245 °C

Profile Feature	Sn-Pb Eutectic Assembly	Pb-Free Assembly
Preheat / soak		
Temperature minimum ( $T_{smin}$ )	100°C	150°C
Temperature maximum ( $T_{smax}$ )	150°C	200°C
Time ( $T_{smin}$ to $T_{smax}$ ) ( $t_s$ )	60 - 120 sec.	60 - 120 sec.
Average ramp-up rate ( $T_{smax}$ to $T_p$ )	3°C/sec. max	3°C/sec. max
Liquidous temperature ( $T_L$ )	183°C	217°C
Time at liquidous ( $t_L$ )	60 - 150 sec.	60 - 150 sec.
Peak package body temperature ( $T_p$ )*	see Table 1	see Table 2
Time ( $t_p$ )** within 5°C of the specified classification temperature ( $T_c$ )	20 sec.	30 sec.
Ramp-down rate ( $T_p$ to $T_{smax}$ )	6°C/sec. max	6°C/sec. max
Time 25°C to peak temperature	6 min. max	8 min. max
Reflow cycles	2 max	2 max

\*Tolerance for peak profile temperature ( $T_p$ ) is defined as a supplier minimum and a user maximum.

\*\*Tolerance for time at peak profile temperature ( $t_p$ ) is defined as supplier minimum and a user maximum.

# ABS07-120-32.768kHz-T; TUNING FORK CRYSTAL

32.768kHz SMD; ESR OPTIMIZED CRYSTAL



3.2 x 1.5 x 0.9 mm

## TAPE & REEL:

T=Tape and reel (3,000pcs/reel)  
T9=Tape and reel (9,000pcs/reel)

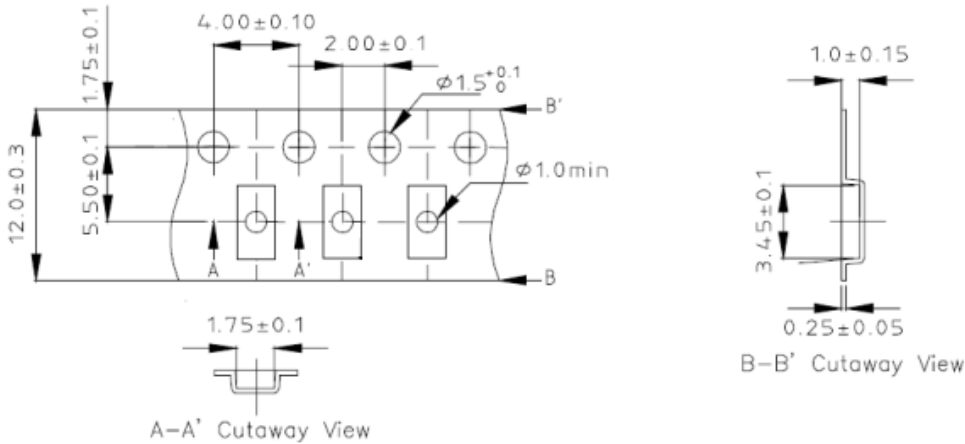

Reel=3,000pcs

REEL : 3000PCS

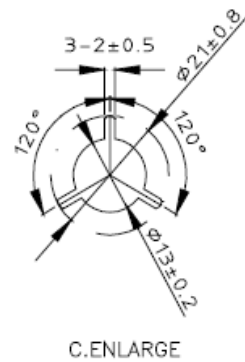
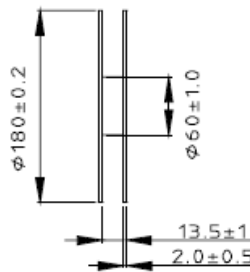
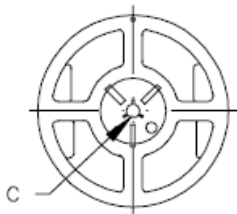

Reel=9,000pcs

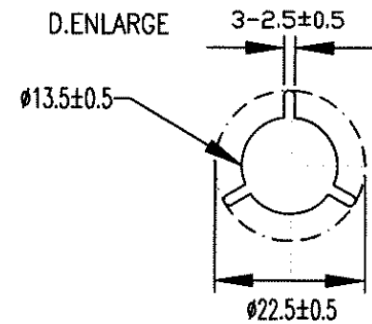
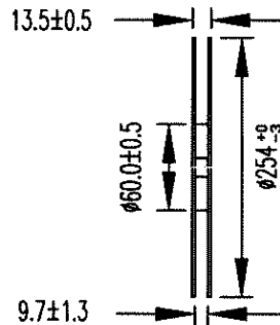
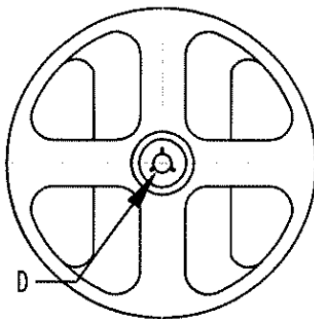

Dimensions: mm

**ATTENTION:** Abracon LLC's products are COTS – Commercial-Off-The-Shelf products; suitable for Commercial, Industrial and, where designated, Automotive Applications. Abracon's products are not specifically designed for Military, Aviation, Aerospace, Life-dependent Medical applications or any application requiring high reliability where component failure could result in loss of life and/or property. For applications requiring high reliability and/or presenting an extreme operating environment, written consent and authorization from Abracon LLC is required. Please contact Abracon LLC for more information.



5101 Hidden Creek Ln Spicewood TX 78669  
Phone: 512-371-6159 | Fax: 512-351-8858  
For terms and conditions of sales, please visit:  
[www.abracon.com](http://www.abracon.com)

REVISED: 05-26-21

ABRACON IS  
ISO9001-2015  
CERTIFIED