

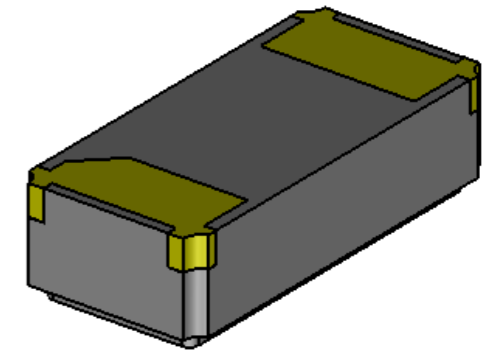

CONNECTIONS

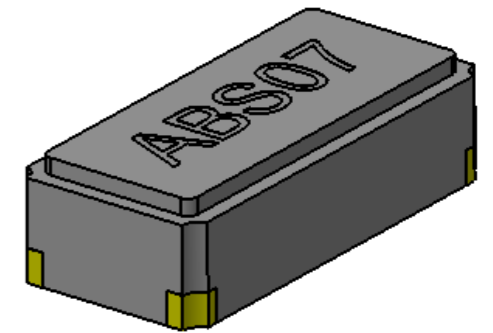
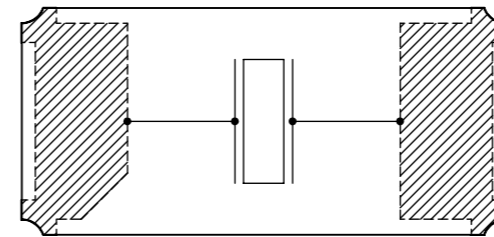

UNLESS OTHERWISE SPECIFIED: DIMENSIONS ARE IN INCH(MM) SURFACE FINISH: TOLERANCES: LINEAR: ANGULAR:				FINISH:		DEBUR AND BREAK SHARP EDGES		DO NOT SCALE DRAWING		REVISION -			
DRAWN XXXXXX				SIGNATURE		DATE		 30332 Esperanza, Rancho Santa margarita, California 92688		TITLE: ABS07 Quartz Crystal			
CHK'D XXXXXX				APPV'D		MFG				DWG NO. ABS07		A3	
Q.A				MATERIAL: Quartz		WEIGHT:				SCALE:20:1		SHEET 1 OF 1	